

STRONG CONNECT

BY NORDEON

EXPERIENCE BRANDS
HESI DRIVEN IS | WILIA LAMP | HEBIN Vulkan

WHY?

STRONG CONNECT

ENVIRONMENTALLY FRIENDLY

30% less steel than competitors



WHY?
STRONG CONNECT

EASY TO INSTALL

Quick Connect Trunking with Locking Rail - mechanical & electrical connection

WHY?
STRONG CONNECT

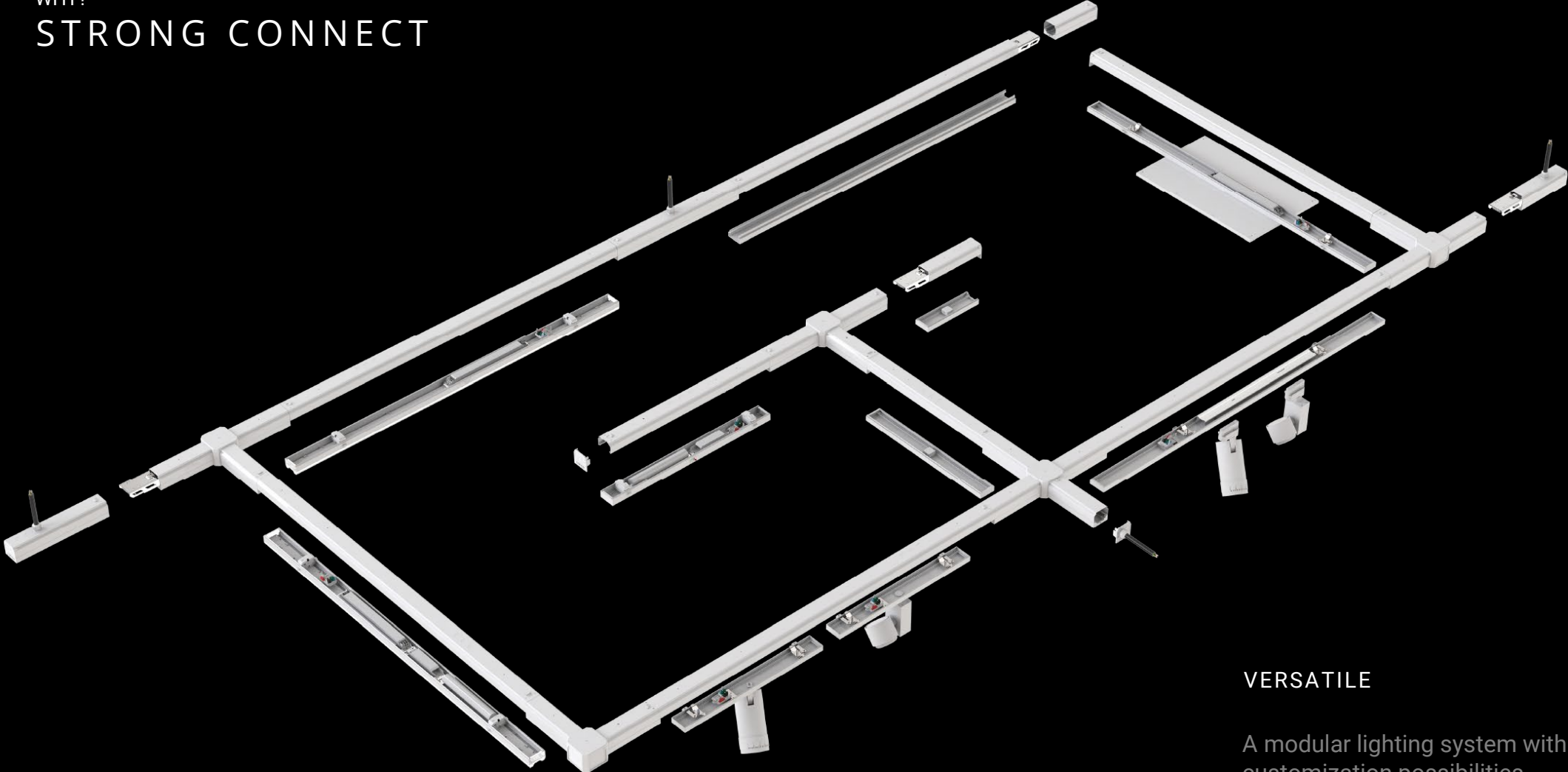

VERSATILE

A modular lighting system with unlimited customization possibilities

Lighting options include: Single Spot, Double Spot, Wall Wash, Occupancy/Daylight Sensor, Gobo Projector



POWERFUL

Up to 150 Lumens per Watt

1250 or 1800 lumens per foot output options

WHY?

STRONG CONNECT



SAFETY

Emergency available as standard

Test Button on side of Trunk



CONFIGURABLE OPTICS

Wide, Medium, Narrow, Batwing (Double Asymmetric), Wall Wash, Diffused

WHY?
STRONG CONNECT

ADAPTABLE

Available in more lengths as standard than the competition: 2", 4", 6", 8", 12"

Can be installed Flush, Semi-Flush & Suspended



STRONG CONNECT

BY NORDEON 

EXPERIENCE
BRANDS
Hess Griven  WOLA  LAMP  Vulkan 